

* WHEN EZ_ONBUS IS LOW, EZ80 WILL DRIVE THE ADDRESS/CONTROL BUS
 * WHEN EZ_ONBUS IS HIGH, EZ80 IS ISOLATED AND CAN ONLY ACCESS ITS INTERNAL ROM/RAM/IO

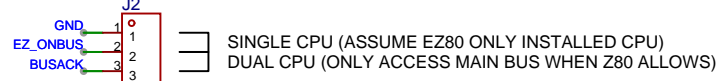

TODOS:
 1. Reduce drill size for pcb pins?
 2. Map INSTRD to M1

1. Use Round Machine Sockets for CPU's socket
2. To take pins to be diameter between 15mil (0.38mm) and 25mil (0.635mm)

EZ80-INTERFACE-V2

1 MAIN

Created:	2024-05-13
Updated:	2024-06-01
Version:	V1.0
Count:	3

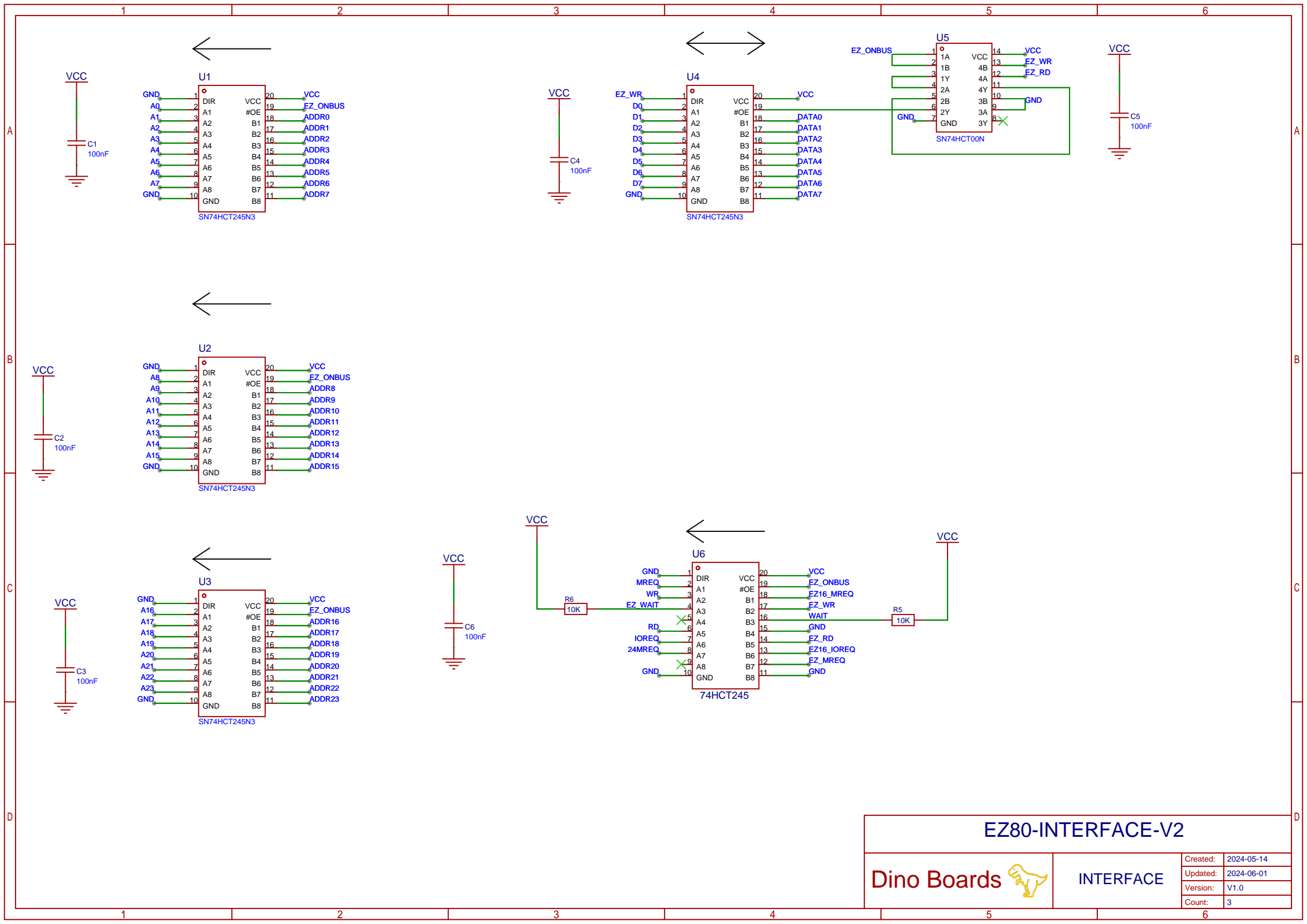

EZ80-INTERFACE-V2

Dino Boards 

INTERFACE

Created:	2024-05-14
Updated:	2024-06-01
Version:	V1.0
Count:	3

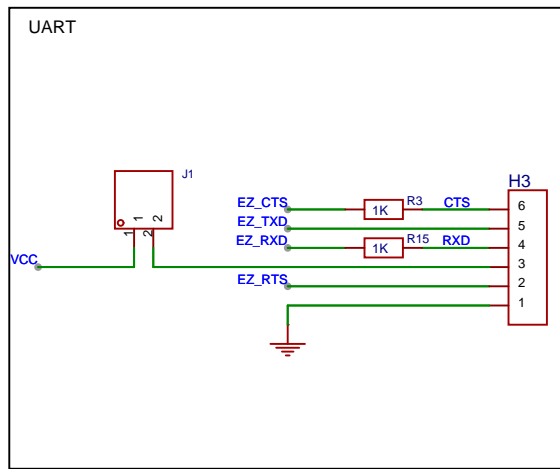
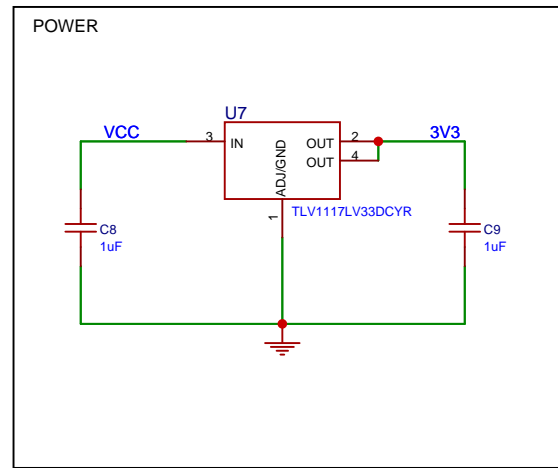
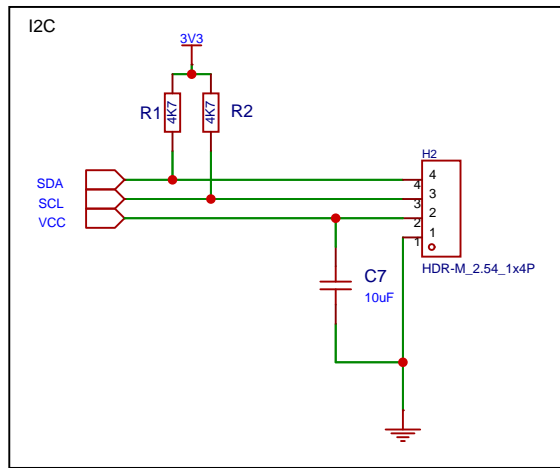

EZ80-INTERFACE-V2

	3 ON-BOARD.EZ80-INTERFACE-V2	Created: 2024-05-14
		Updated: 2024-05-01
		Version: V1.0
		Count: 3